

DIMENSIONI ATTUATORE LINEARE "ASSL1"

"ASSL1" actuator dimensions

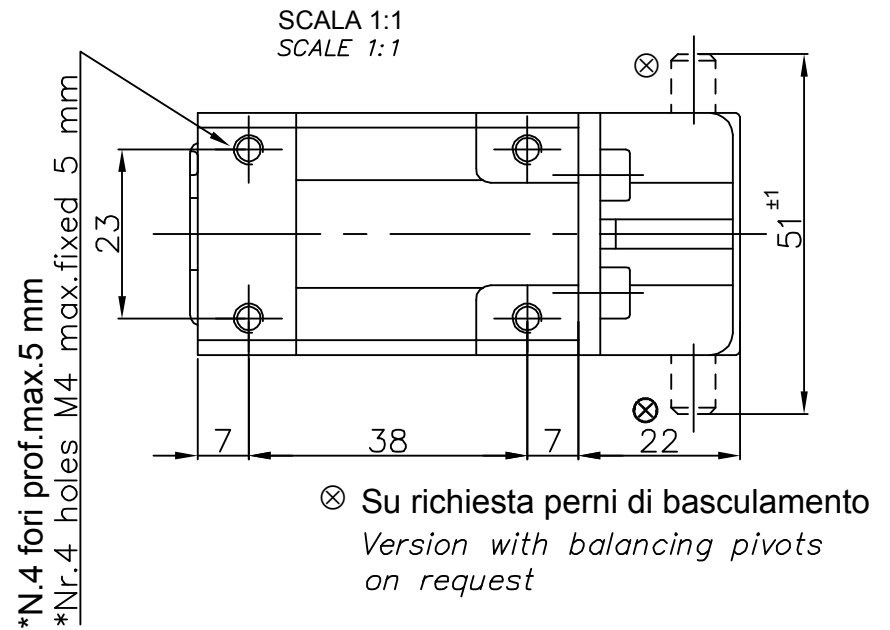
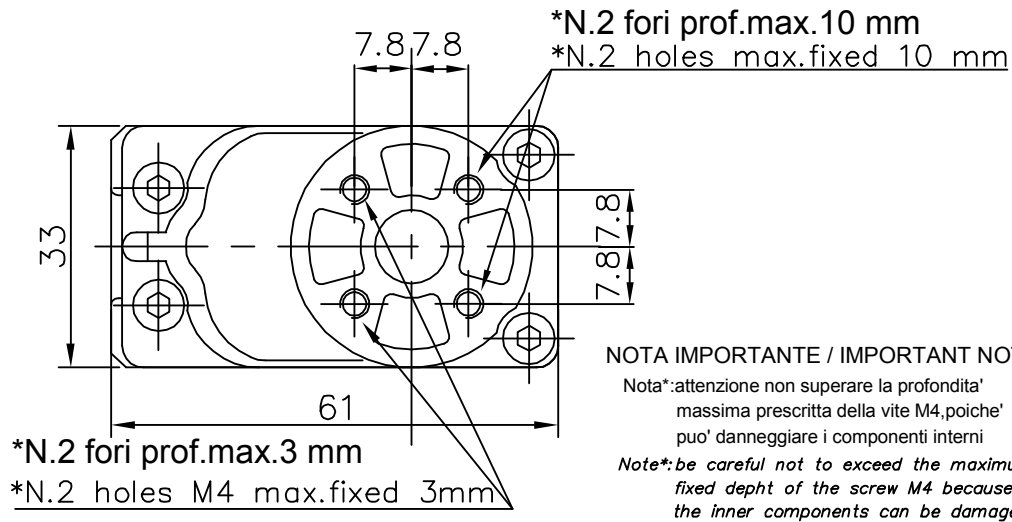

SOLUZIONI STANDARD ATTACCHI VITE STANDARD SOLUTIONS FIXING SCREW

1[^] soluzione
1[^] solution

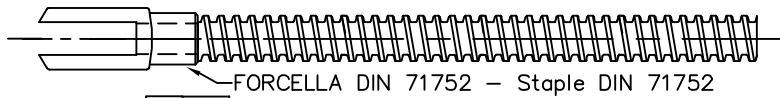

2[^] soluzione
2[^] solution

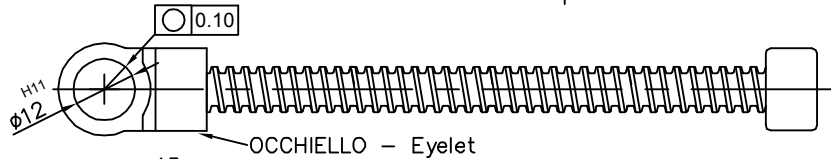

3[^] soluzione
3[^] solution

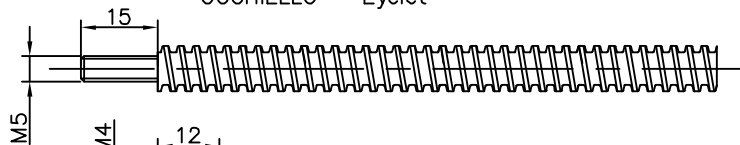

4[^] soluzione
4[^] solution

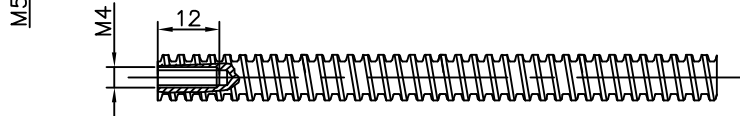

TIPI DI VITE TRAPEZIA DISPONIBILI / TRAPEZOIDAL SCREWS AVAILABLE

- Ø8,7 PASSO 3 - PITCH 3 (AISI 430F)
- Ø9,8 PASSO 3 - PITCH 3 (AISI 430F)
- Ø7,9 PASSO 10 - PITCH 10 (AISI 430F)

